

Helping Customers Innovate, Improve & Grow



AR-51-07

Features

- GPS disciplined Rubidium clock
- Outputs: 10MHz, 1PPS (TTL & RS-422), TOD (Have Quick), 2PPS (opt.)
- Input: GPS antenna, 1PPS, TOD (Have Quick)
- Frequency Accuracy : 2E-12
- 1PPS Accuracy: Typ. 20ns (RMS)
- NTP Server. Time Accuracy <300 μ s (opt)
- Holdover (no GPS): Typ. 1 μ s/24 hours, 5E-11/month
- Operating Temperature: -25°C to +65°C (71°C Emergency). -40°C (opt.)
- Control and monitoring : RS-232 (input & output), RS-422 (output), MIL-STD-1553 (opt.)
- Ephemeris, Almanac & Ionosphere Data
- Supply Voltage: 22-32 VDC per MIL-STD-704D
- External battery input for power back-up
- P(Y) code GPS (SAASM) receiver (Option)
- Full MIL-STD qualification for military Airborne Applications
- Graphic User Interface (GUI) Software for PC

Application

- Communication
- Telemetry test fields
- Field calibration

Description

The AR-51-07 unit is an industrial low profile GPS-Disciplined Rubidium Clock which offers an excellent stability and accuracy. The unit includes a Rubidium-Atomic-Standard which is phase-locked to the GPS or other external inputs. All outputs are derived from the Rubidium-Atomic-Standard and maintain highly accurate time and frequency even when GPS reception is interrupted. When disciplined to GPS the unit provides time accuracy of < 20ns RMS and frequency accuracy better than 2E-12.

The AR-51-07 includes Have Quick (ICD-GPS-060) input and output which is essential for secure radio communication applications. The unit can be remote controlled via MIL-STD-1553RT channel which is required in airborne applications.

The unit includes internal GPS receiver (C/A code) and have option to install P(Y) code SAASM GPS receiver (For more information contact factory).

The AR-51-07 is designed for demanding platforms such as airborne, helicopters, UAV's, shipboard and ground mobile.

Performance Specifications

All specifications are at room temperature, quiescent conditions, sea level ambient unless otherwise specified

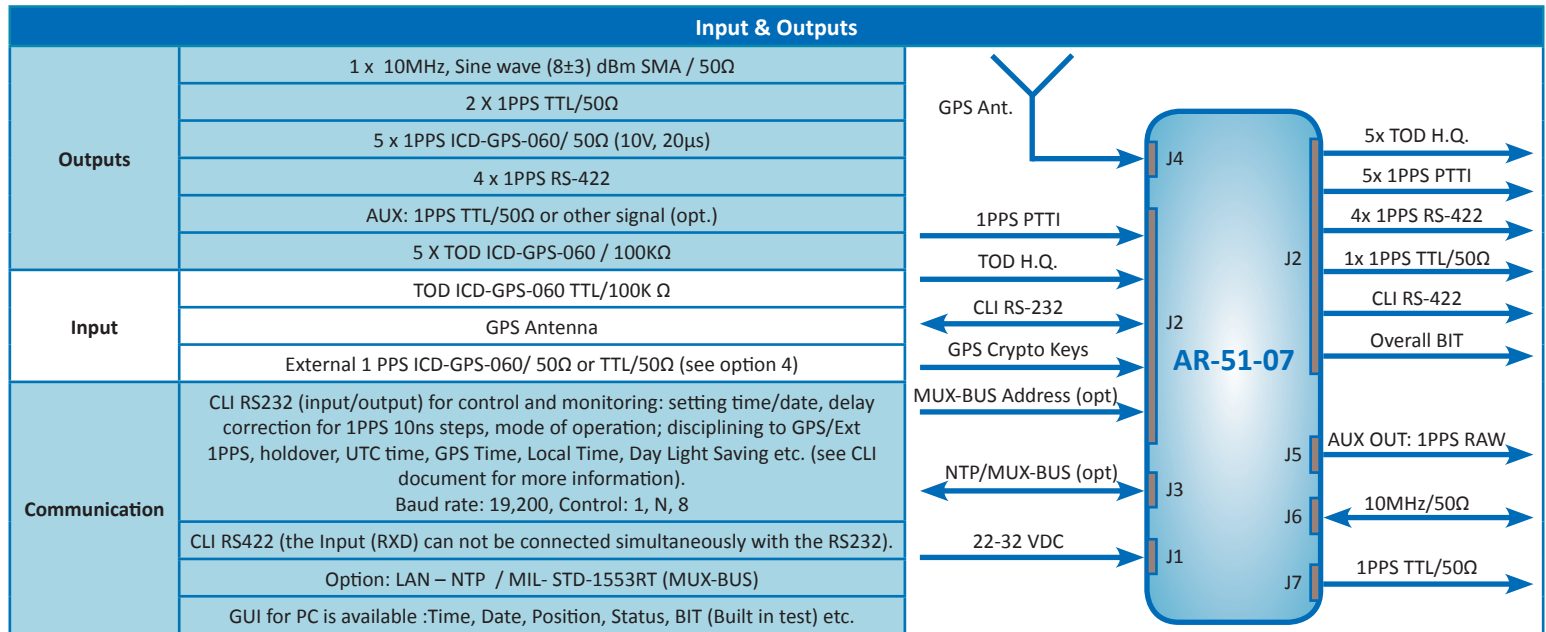

| | | Performance | | | | |
|--------------------------|--|---|-----------------|---|--------------------|--|
| Time (1PPS) | Long Term Accuracy | Disciplined to GPS or to an External synchronization source | | 50ns RMS (typ. 20ns RMS) @ 25°C, relative to an external ref. | | |
| | | Time Drift without GPS (Hold-Over) | | < 1μs/24hr (Typ.) | | |
| Frequency (10MHz) | Long Term Stability | Disciplined to GPS or to Ext. 1PPS | | < 2E-12 (24 hour average, const temp.) | | |
| | | Free running Rubidium-Standard | | 5E-11 / month drift in holdover | | |
| | Short Term Stability | ≤ 4E-11 @ 1s (≤3E-11 Typ.) | | | | |
| | Temperature Stability | ±3E-10 over -25°C to +65°C (-40°C opt.) | | | | |
| | Phase Noise | Frequency | Standard (spec) | Standard (typical) | Improved (typical) | |
| | | 1Hz | | | -96/Hz | |
| | | 10Hz | ≤-100dBc/Hz | -101dBc/Hz | -128/Hz | |
| | | 100Hz | ≤-134dBc/Hz | -137dBc/Hz | -148/Hz | |
| | | 1KHz | ≤-143dBc/Hz | -144dBc/Hz | -150/Hz | |
| | 10KHz | ≤-145dBc/Hz | -149dBc/Hz | -153/Hz | | |
| Harmonics | ≤-45 dBc (-58 dBc typ.) | | | | | |
| Spurious | <-75 dBc @ ± 100KHz from carrier | | | | | |
| Warm-up | Rb Lock < 4 min 5E-10 within < 7 min 5E-11 within < 60 min, 1E-11 within < 4hrs 2E-12 within < 24 hrs. | | | | | |
| Retrace | ± 4E-11 | | | | | |

| Power Supply | |
|------------------------|---|
| Input Voltage | 22-32 VDC (28 VDC Typ.) per MIL-STD-704D |
| Power | < 30 Watt @ 28 VDC (warm-up) < 14 Watt @ 28 VDC @ 25°C (steady-state) |
| Battery Back-Up | External power input for battery back-up via the main power inlet Automatically operated when the main power reduces to 24 VDC |

Performance Specifications (continued)

Industrial GPS Receiver (MIL-P (Y) code as an option)

| | |
|---------------------------------------|--|
| Tracking | L1 frequency (1575 MHz), C/A code 12 parallel tracking channels L1/L2 frequency P(Y) code SAASM 12 parallel tracking channels as an option (For more information contact factory) |
| Position | Lat., long., alt. |
| Position Accuracy (Lat long) | 6m CEP (50%) w/o SA |
| Position Accuracy (Alt) | 11m CEP (50%) w/o SA |
| GPS Antenna DC Voltage | 5V |
| Acquisition Time | Warm start 45 second, Cold start < 50 second (worst case) |

Dimensions & Weight

| | |
|-------------------|-------------------------------------|
| Dimensions | 245 mm (w) x 166 mm (h) x 56 mm (d) |
| weight | 1.5 Kg |

Environmental

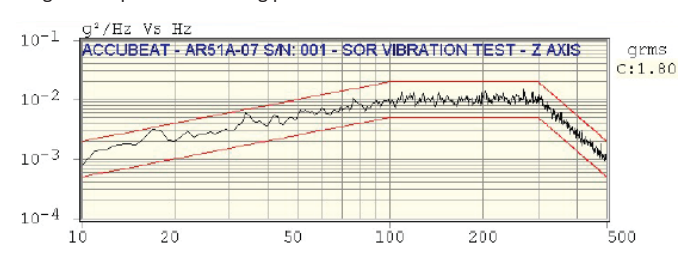
| Temperature | Operating: -25°C to +65°C (-40°C to +65°C Opt.) Emergency: +71°C for 60 minutes Storage: -40°C to +71°C | | | | | | | | | | | | | | | | | | | | | | | | | | | |
|---|--|------------|--|--|-----------|-----|------------|------|------|------|-------|--|--|------|-----|-----|------|------|------|-------|------|------|-------|------|------|-------|------|------|
| Temperature Altitude | -40°C to +65°C (+71°C for 60 minutes) 0 to 60,000 ft | | | | | | | | | | | | | | | | | | | | | | | | | | | |
| Humidity | 95% non condensing | | | | | | | | | | | | | | | | | | | | | | | | | | | |
| Random Vibration (Without vibration absorbers. For more details on the vibration absorbers option – please see the Accessories chapter below) | <p>2.45gRMS as per the following profile:</p>  <table border="1" data-bbox="1247 993 1539 1255"> <thead> <tr> <th colspan="3">GRMS</th> </tr> <tr> <th>TOTAL Con</th> <th>Ref</th> <th>RANDOM Con</th> </tr> </thead> <tbody> <tr> <td>2.45</td> <td>1.79</td> <td>1.80</td> </tr> <tr> <th colspan="3">TONES</th> </tr> <tr> <th>Freq</th> <th>Ref</th> <th>Con</th> </tr> <tr> <td>4.30</td> <td>0.11</td> <td>0.11</td> </tr> <tr> <td>17.20</td> <td>1.21</td> <td>1.23</td> </tr> <tr> <td>34.40</td> <td>1.75</td> <td>1.77</td> </tr> <tr> <td>51.60</td> <td>1.05</td> <td>1.03</td> </tr> </tbody> </table> | GRMS | | | TOTAL Con | Ref | RANDOM Con | 2.45 | 1.79 | 1.80 | TONES | | | Freq | Ref | Con | 4.30 | 0.11 | 0.11 | 17.20 | 1.21 | 1.23 | 34.40 | 1.75 | 1.77 | 51.60 | 1.05 | 1.03 |
| GRMS | | | | | | | | | | | | | | | | | | | | | | | | | | | | |
| TOTAL Con | Ref | RANDOM Con | | | | | | | | | | | | | | | | | | | | | | | | | | |
| 2.45 | 1.79 | 1.80 | | | | | | | | | | | | | | | | | | | | | | | | | | |
| TONES | | | | | | | | | | | | | | | | | | | | | | | | | | | | |
| Freq | Ref | Con | | | | | | | | | | | | | | | | | | | | | | | | | | |
| 4.30 | 0.11 | 0.11 | | | | | | | | | | | | | | | | | | | | | | | | | | |
| 17.20 | 1.21 | 1.23 | | | | | | | | | | | | | | | | | | | | | | | | | | |
| 34.40 | 1.75 | 1.77 | | | | | | | | | | | | | | | | | | | | | | | | | | |
| 51.60 | 1.05 | 1.03 | | | | | | | | | | | | | | | | | | | | | | | | | | |
| Mechanical Shock - Operation | MIL-STD-810C/E, Method 516.2, Proc. 1 (15g / Half sine/ 3 axis/ 6 shocks per axis) | | | | | | | | | | | | | | | | | | | | | | | | | | | |
| Mechanical Shock - crash | X-40G, Y-15G, Z-20G, 11ms, Half Sine, Total 12 shocks | | | | | | | | | | | | | | | | | | | | | | | | | | | |
| Bench Handling Shock | MIL-STD-810C/E, Method 516.2, Procedure V | | | | | | | | | | | | | | | | | | | | | | | | | | | |
| Rain | MIL-STD-810E Method 506.3 procedure I | | | | | | | | | | | | | | | | | | | | | | | | | | | |
| Dust | MIL-STD-810E Method 510.3 | | | | | | | | | | | | | | | | | | | | | | | | | | | |
| Salt Atmosphere | MIL-STD-810E, Method 509.3, Procedure I | | | | | | | | | | | | | | | | | | | | | | | | | | | |
| Bonding | ≤2.5 mΩ | | | | | | | | | | | | | | | | | | | | | | | | | | | |
| EMI / RFI | MIL-STD-461B/C Part: 5 (CE01, CE03, CE07, RE02, CS01, CS02, CS06, RS02, RS03) | | | | | | | | | | | | | | | | | | | | | | | | | | | |

Reliability, Maintainability, Testability

| | |
|----------------------------|---|
| MTBF | > 20,000 hours @ 30°C, ARW, MIL-HBK-217F |
| MTTR – O Level | 12 min. to replace failed unit (including warm-up time) |
| MTTR – I Level | 34 min. to replace failed module (including warm-up time) |
| BIT (Built In Test) | On-line BIT – Automatic, Covers 90% of all failures |

Principles of Operation

The following block diagrams depict the operation of the AR-51-07. The unit includes Rubidium Standard and accepts Input from internal GPS receiver, external 1PPS or external TOD (H.Q). All outputs are derived from the internal Rubidium Clock, which is phase locked by a digital PLL to the selected input. Thus, the Rubidium Clock - frequency and time - follows the GPS on the long term average. If GPS reception is lost for short or long periods of time the Rubidium Clock shall maintain accurate time and frequency with no phase interruption.

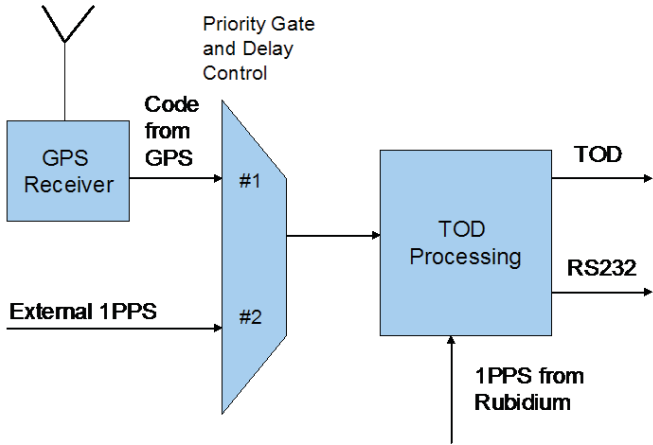

Data flow & Inputs Selection

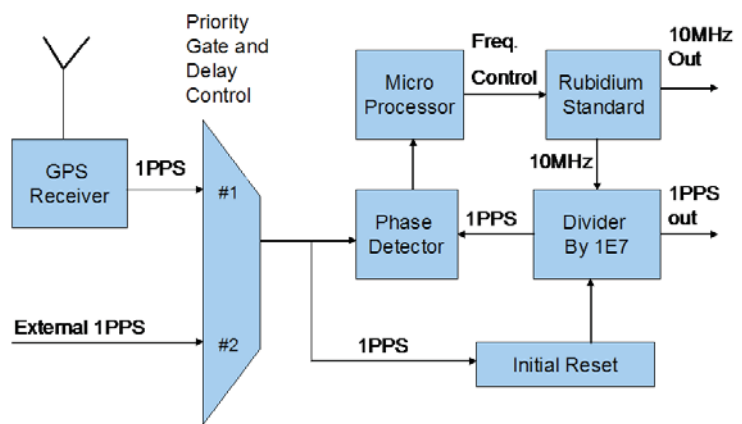

Rubidium-GPS D-PLL and Inputs

Typical Performance Plots

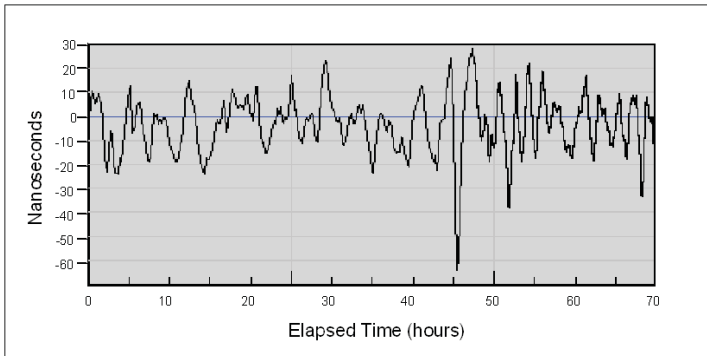

Typical time error fluctuations when disciplined to GPS

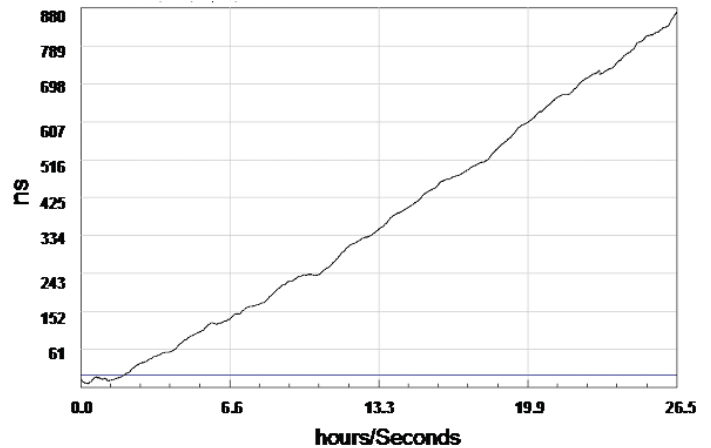

Typical time error in Holdover (without GPS)

Typical Performance Plots

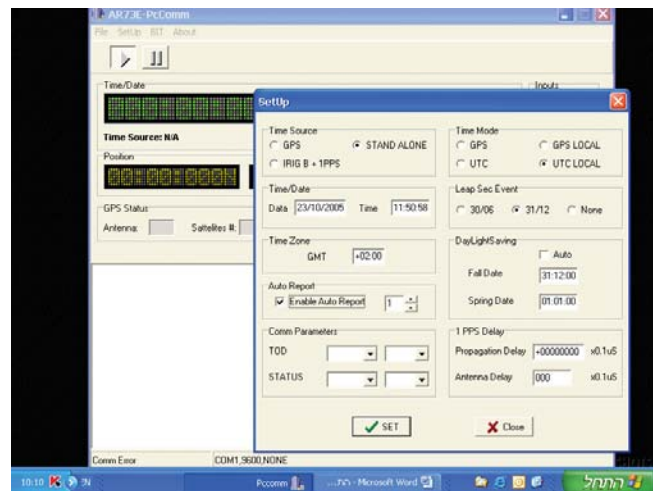
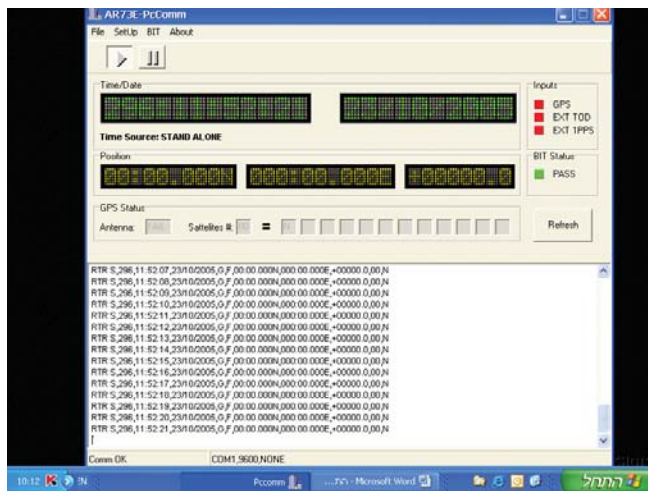

Mechanical ICD

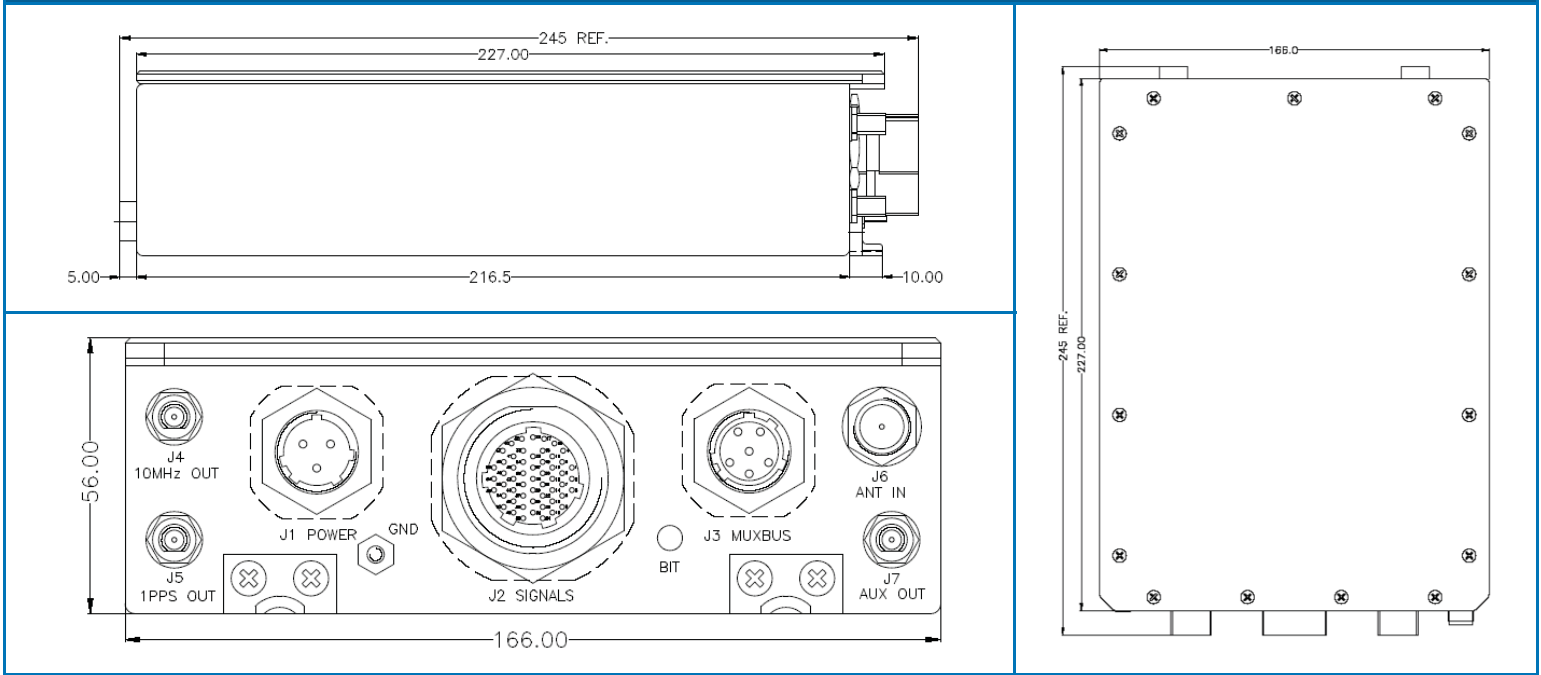

Electrical ICD

| Electrical ICD | | I/O |
|-----------------|--------------------------------------|--------|
| Connector | | I/O |
| J1 - Supply | | OUT |
| J2 - Signals | TOD TTL/100K ohm x 5 | OUT |
| | 1 PPS PTTI x 5 | OUT |
| | 1 PPS RS-422 x 4 | OUT |
| | 1 PPS TTL/50 ohm x 1 | OUT |
| | Aux RS-422 x 1 | IN/OUT |
| | CLI RS-232 x 1 | IN/OUT |
| | 1PPS ICD-GPS-060 x 1 | IN |
| | TOD TTL/100K ohm x 1 | IN |
| | MUX-Bus Address | IN |
| | Overall BIT | OUT |
| GPS crypto keys | IN/OUT | |
| J3 - MUXBUS | MIL-STD-1553RT, Female | IN/OUT |
| J4 - 10MHz OUT | Sine-wave, 8 ±3dBm, 50Ω, SMA, Female | OUT |
| J5 - 1PPS OUT | TTL/50 ohm, SMA, Female | OUT |
| J6 - ANT IN | L1/L2, TNC, 50Ω, Female | IN |
| J7 - AUX OUT | 1PPS TTL/50 ohm (RAW), SMA, Female, | OUT |



The tray should be use in harsh environmental where high vibration level is applied, the absorber dramatically decrease the vibration level, so the clock obtain lower vibration level. The mechanical design of the tray, allows rapid connection and disconnection of the clock from the tray, without use of any working tools.

For more details – contact factory.

Mechanical ICD

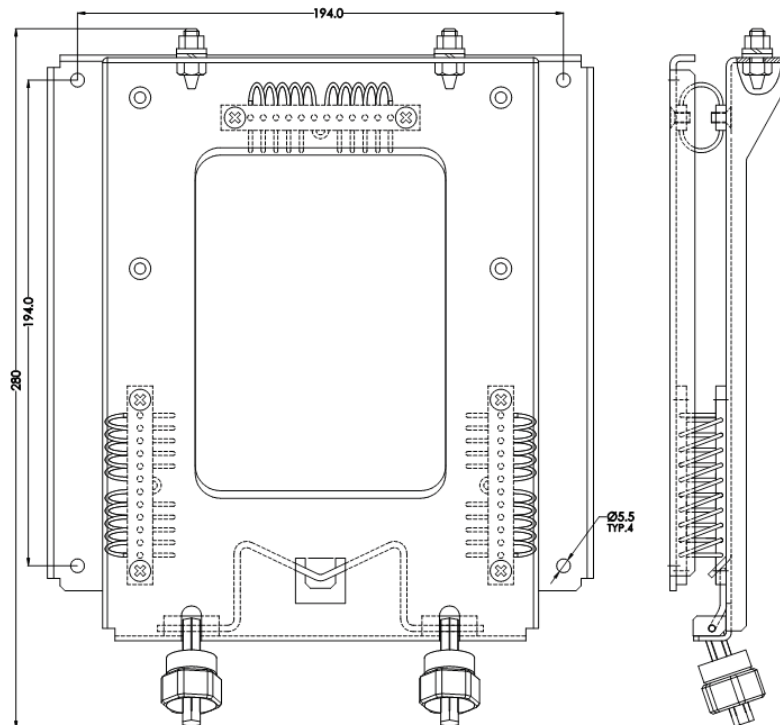
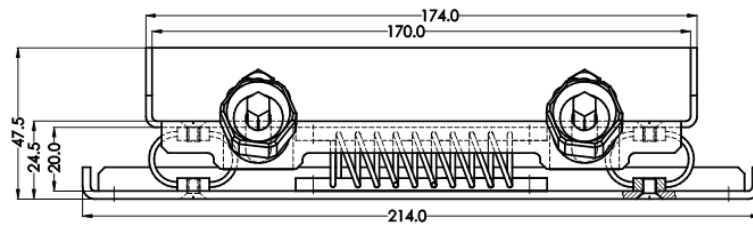

How To Order

| Vectron P/N | Options Descriptions | | | | | | | |
|--|------------------------------|-------------------|---|------------------------|------------------|----------------------------------|-------------------|-----------------------------|
| | C(A) code GPS | P(Y) code GPS (*) | LAN channel (NTP & UDP) | Temperature Range (**) | RS422 COM. (CLI) | Ephemeris & Almanac data (RS422) | Humidity (RH) | Improved Phase Noise & ADEV |
| AR-51-07-02 | √ | - | - | -25°C to +65°C | √ | - | 95% | - |
| AR-51-07-04 | √ | - | - | | √ | - | | √ |
| AR-51-07-08 | √ | √ | √ | -40°C to +65°C | √ | - | | √ |
| AR-51-07-09 | - | - | √ | -25°C to +65°C | √ | - | 98% Condensing | - |
| AR-51-07-10 | √ | - | - | -40°C to +65°C | √ | - | 95% | - |
| AR-51-07-xx | - | - | GPS-Rb with P(Y) code SAASM GPS - For more information contact factory. | | | | | |
| Vibration absorber | Vectron part number: MU50015 | | | | | | | |
| * For other customized configuration, 1553 MUX BUS protocol, and for more options - please contact factory. | | | | | | | | |

NOTE: For the P(Y) code receiver option, the customer need to supply the receiver.

Revision History

| Revision | Change Summary | Date |
|----------|-----------------|--------------|
| 1.0 | Product Release | October 2014 |
| | | |
| | | |
| | | |

For Additional Information, Please Contact

USA:

Vectron International
267 Lowell Road, Suite 102
Hudson, NH 03051
Tel: 1.888.328.7661
Fax: 1.888.329.8328

Europe:

Vectron International
Landstrasse, D-74924
Neckarbischofsheim, Germany
Tel: +49 (0) 7268.801.100
Fax: +49 (0) 7268.801.282

Asia:

68 Yin Cheng Road(C), 22nd Floor
One Lu Jia Zui
Pudong, Shanghai 200120, China
Tel: +86 21 6194 6886
Fax: +86 21 6194 6699

Disclaimer

Vectron International reserves the right to make changes to the product(s) and or information contained herein without notice. No liability is assumed as a result of their use or application. No rights under any patent accompany the sale of any such product(s) or information.