

# Handling Freescale Pressure Sensors

by: William McDonald

## INTRODUCTION

Smaller package outlines and higher board densities require the need for automated placement of components. These components are supplied in embossed carrier tape on plastic reels to meet the increased demand and facilitate ease of handling. This application note is intended to provide general information and understanding for handling Freescale's surface mount pressure sensors. Equipment details are not provided in this document and it is recommended that end users contact suppliers of equipment for specific applications.

## METHODS OF HANDLING

Components can be picked from the carrier tape using either the vacuum assist or the mechanical type pick up heads. A vacuum assist nozzle type is most common due to its lower cost of maintenance and ease of operation. The recommended vacuum nozzle configuration should be designed to make contact with the device directly on the metal

cover and avoid vacuum port location directly over the vent hole in the metal cover of the device. To provide a more secure hold on the device, contact with the plastic ridge around the perimeter of the metal cover should be avoided to prevent loss of vacuum pressure. Multiple vacuum ports within the nozzle may be required to effectively handle the device and prevent shifting during movement to placement position.

Figure 1 shows two styles of multiple port vacuum nozzles for the MPXH series device as an example. Figure 2 represents the nozzle location on the device.

Vacuum pressure required to adequately support the component should be approximately 25 in Hg (85kPa). This level is typical of in-house vacuum supply.

Pick up nozzles are available in various sizes and configurations to suit a variety of component geometries. To select the nozzle best suited for the specific application, it is recommended that the customer consult their pick and place equipment supplier to determine the correct nozzle. In some cases it may be necessary to fabricate a special nozzle depending on the equipment and speed of operation.

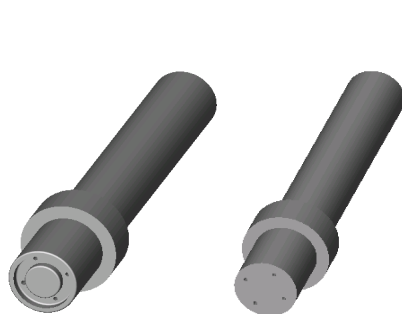


Figure 1. MPXH Series Multiple Port Vacuum Nozzles

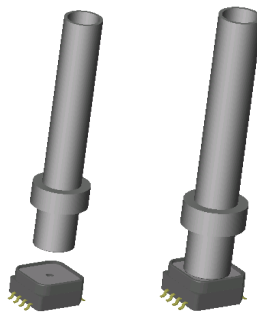


Figure 2. Nozzle Location

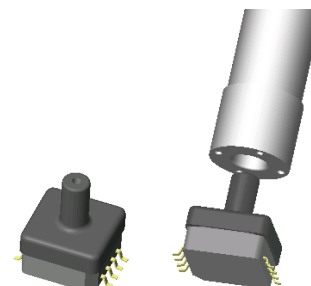


Figure 3. SSOP Axial Style Port

## AVAILABLE PACKAGES

Freescale offers several small outline surface mount device families. These are MPXA, MPXH, MPXM, and MPXY series of devices.

These devices are also available in axial ported versions to allow pressure to be interfaced to a device via a hose connection.

Pick up nozzles for these packages should be configured to apply vacuum only to the flat surface of a port base. An access clearance in the nozzle for a port shank is necessary to properly handle these device configurations. See Figure 3.



SOP



SSOP



MPAK

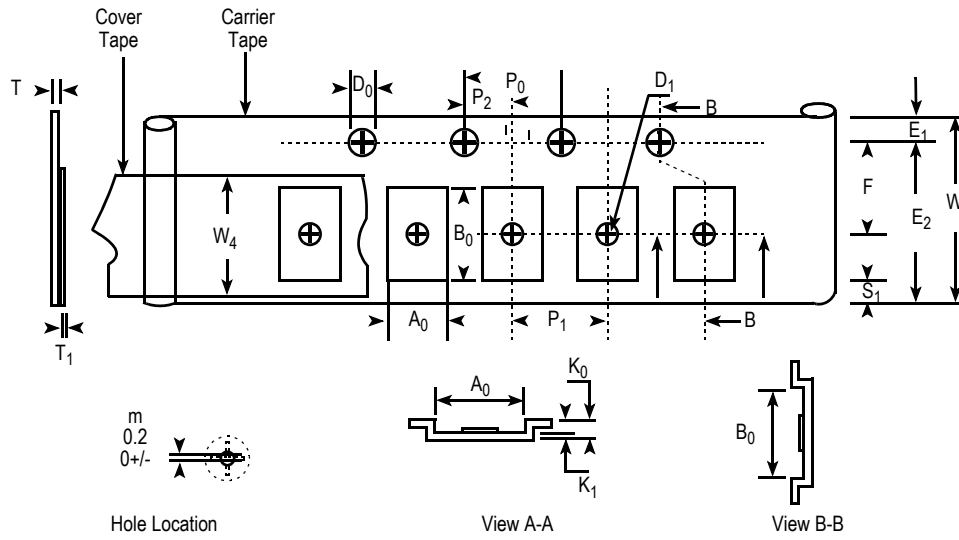


SOIC16

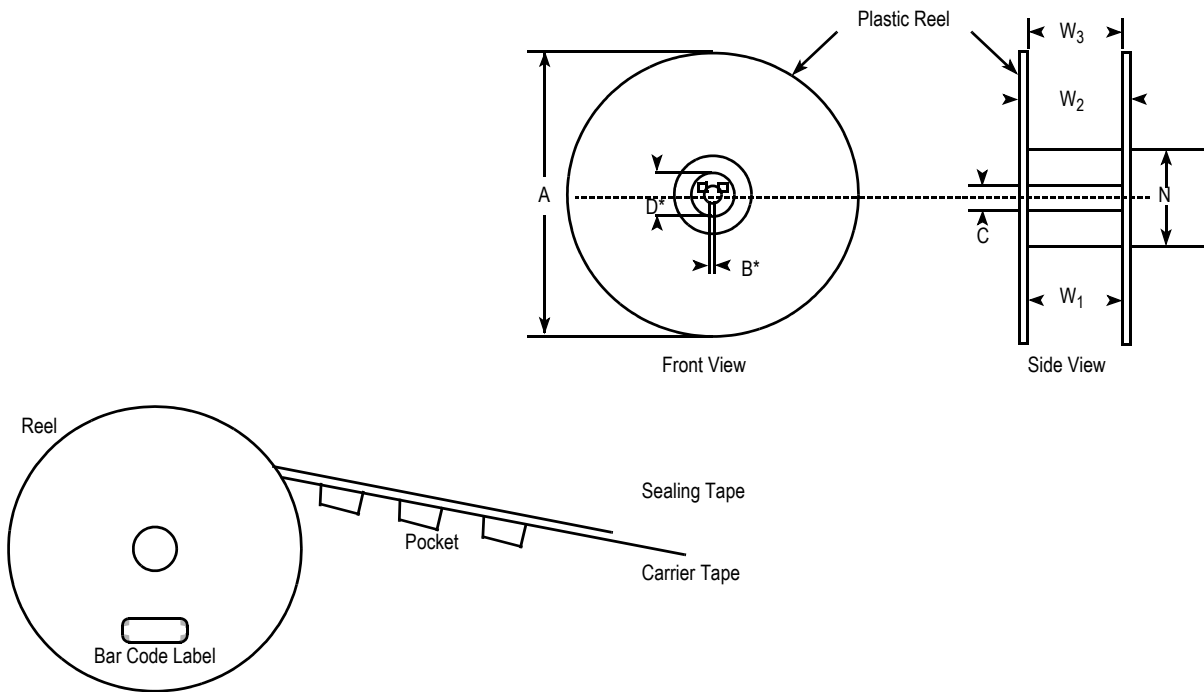
Figure 2. Available Packages

Table 1. Tape and Reel Information

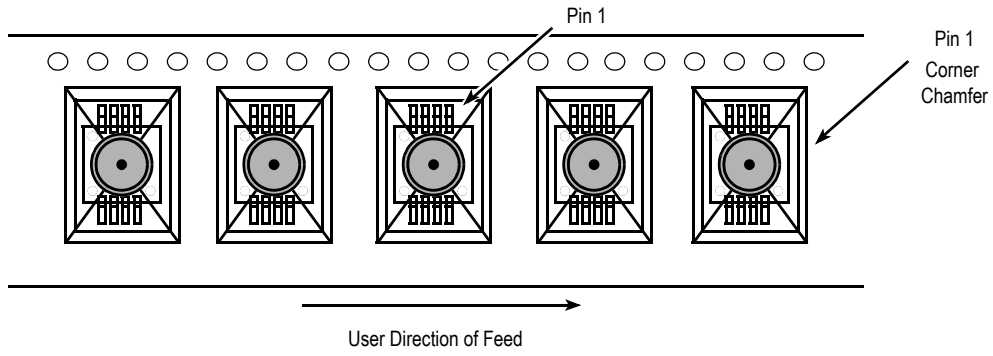
	Case	423A	1317	1317A	1320	1320A	482	482A	1369
<b>Carrier Tape</b>		<b>Chip Pak</b>	<b>SSOP</b>	<b>SSOP Ported</b>	<b>M-Pak</b>	<b>M-Pak Ported</b>	<b>SOP</b>	<b>SOP Ported</b>	<b>SOP Side Port</b>
Tape Width	W	24.0+/-0.3	24.0+/-0.3	24.0+/-0.3	24.0+/-0.3	24.0+/-0.3	32+/-0.3	32+/-0.3	32+/-0.3
Pocket Width	A <sub>0</sub>	8.5+/-0.2	7.7+/-0.1	8.8+/-0.1	6.8+/-0.1	7.2+/-0.1	11.3+/-0.1	12.0+/-0.2	12.6+/-0.2
Length	B <sub>0</sub>	14.2+/-0.2	10.7+/-0.1	11.8+/-0.1	12.6+/-0.1	13.2+/-0.1	18.9+/-0.1	18.8+/-0.2	18.8+/-0.2
Depth	K <sub>0</sub>	4.7+/-0.1	5.0+/-0.1	10.8+/-0.1	4.6+/-0.1	10.5+/-0.1	6.4+/-0.1	13.8+/-0.1	9.2+/-0.2
Sprocket Hole Pitch	P <sub>0</sub>	4.0 +/-0.1	4.0+/-0.1	4.0+/-0.1	4.0+/-0.1	4.0+/-0.1	4.0+/-0.1	4.0+/-0.1	4.0+/-0.1
Sprocket Hole Diagram	D <sub>0</sub>	1.55+/-0.05	1.55+/-0.05	1.55+/-0.05	1.55+/-0.05	1.55+/-0.05	1.5+/-0.05	1.5+/-0.1	1.5+/-0.1
Edge to Hole	E <sub>1</sub>	1.75+/-0.1	1.75+/-0.1	1.75+/-0.1	1.75+/-0.1	1.75+/-0.1	1.75+/-0.1	1.75+/-0.1	1.75+/-0.1
Hole to Edge	E <sub>2</sub>	22.2 min	22.2 min	22.2 min	22.2 min	22.2 min	N/A	N/A	N/A
Distance between Holes	S <sub>0</sub>	N/A	N/A	N/A	N/A	N/A	28.4+/-0.1	28.4+/-0.1	28.4+/-0.1
Pocket Pitch	P <sub>1</sub>	12.0+/-0.1	12.0+/-0.1	16.0+/-0.1	12.0+/-0.1	16.0+/-0.1	16.0+/-0.1	20.0+/-0.1	24.0+/-0.1
Pocket Position	P <sub>2</sub>	2.0+/-0.1	2.0+/-0.1	2.0+/-0.1	2.0+/-0.1	2.0+/-0.1	2.0+/-0.1	2.0+/-0.1	2.0+/-0.1
	F	11.5+/-0.1	11.5+/-0.1	11.5+/-0.1	11.5+/-0.1	11.5+/-0.1	14.2+/-0.1	14.2+/-0.1	14.2+/-0.1
Tape Thickness	T	0.40+/-0.05	0.40+/-0.05	0.40+/-0.05	0.40+/-0.05	0.40+/-0.05	0.30+/-0.05	0.35+/-0.05	0.40+/-0.05
Distance Pocket to Edge	S <sub>1</sub>	0.6 min.	0.6 min	0.6 min	0.6 min	0.6 min	N/A	N/A	N/A
Pocket Hole Diagram	D <sub>1</sub>	N/A	1.5+/-0.1	1.5+/-0.1	1.5+/-0.1	1.5+/-0.1	2.0+/-0.1	2.0+/-0.1	2.0+/-0.1
<b>Cover Tape</b>									
Thickness	T <sub>1</sub>	0.052 +/-0.01	0.052 +/-0.01	0.052 +/-0.01	0.052 +/-0.01	0.052 +/-0.01	0.052 +/-0.01	0.052 +/-0.01	0.052 +/-0.01
Width	W <sub>4</sub>	21.1+/-0.1	21.1+/-0.1	21.1+/-0.1	21.1+/-0.1	21.1+/-0.1	21.1+/-0.1	25.5+/-0.1	25.5+/-0.1
<b>Reel</b>									
Width at Hub	W <sub>1</sub>	23.7 - 25.2	23.7 - 25.2	23.7 - 25.2	23.7 - 25.2	23.7 - 25.2	23.7 - 25.2	31.7 - 33.2	31.7 - 33.2
Width at outer flange	W <sub>3</sub>	23.7 - 28.0	23.7 - 28.0	23.7 - 28.0	23.7 - 28.0	23.7 - 28.0	23.7 - 28.0	31.7 - 36.0	31.7 - 36.0
Overall Width	W <sub>2</sub>	30.4 max.	30.4 max.	30.4 max.	30.4 max.	30.4 max.	30.4 max.	38.4 max.	38.4 max.
Hub Diagram	N	100+/-2.50	100+/-2.50	100+/-2.50	100+/-2.50	100+/-2.50	100+/-2.50	178+/-2.50	178+/-2.50
Arbor Hole Diagram	C	13.0+ 0.5/-0.2	13.0+ 0.5/-0.2	13.0+ 0.5/-0.2	13.0 +0.5/-0.2	13.0 +0.5/-0.2	13.0 +0.5/-0.2	13.0 +0.5/-0.2	13.0 +0.5/-0.2
Slot of Arbor Hole	B	1.50/2.50	1.50/2.50	1.50/2.50	1.50/2.50	1.50/2.50	1.50/2.50	1.50/2.50	1.50/2.50
Reel Diagram	A	330+/-0.76	330+/-0.76	330+/-0.76	330+/-0.76	330+/-0.76	330+/-0.76	330+/-0.76	330+/-0.76
<b>DEVICE QTY/REEL</b>	MPQ	1000	1000	300	1000	400	600	100	200



**Figure 3. Carrier Tape**

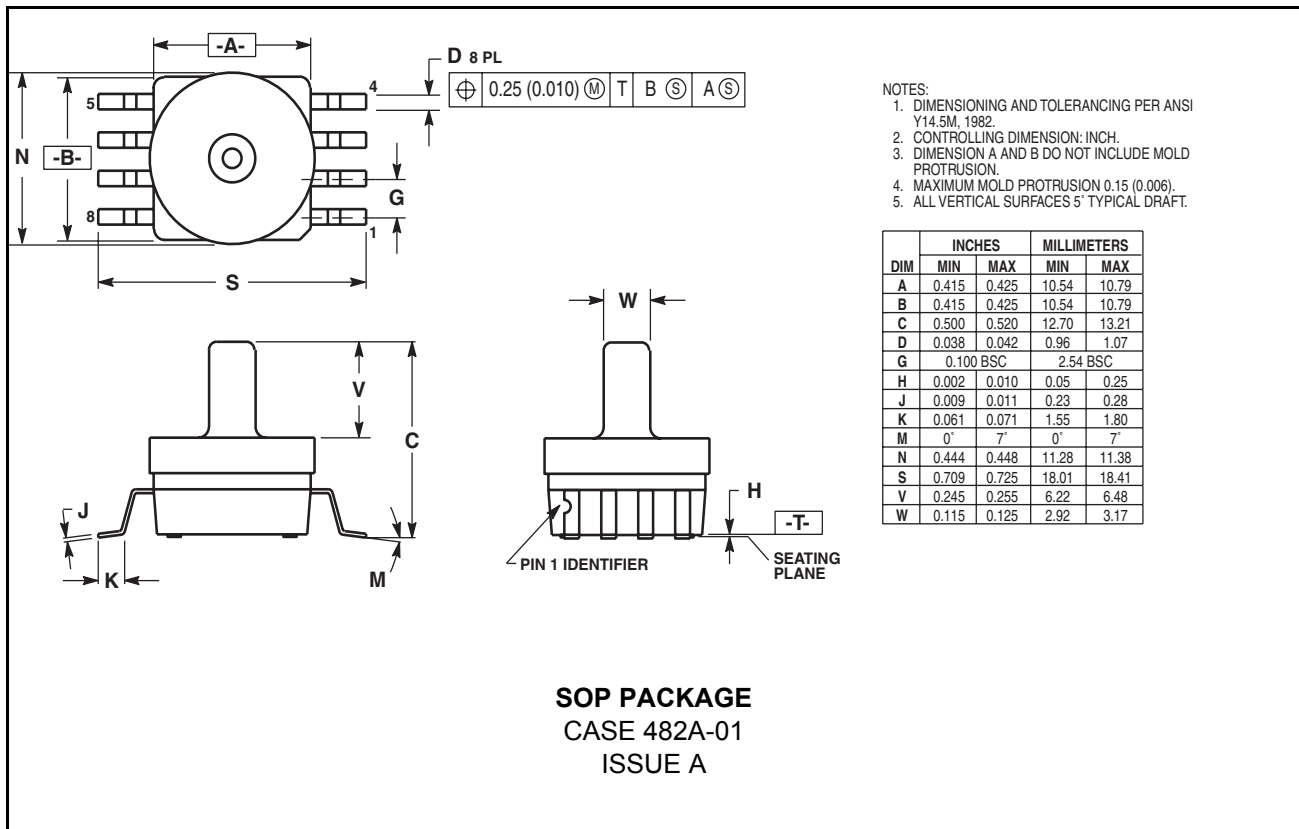
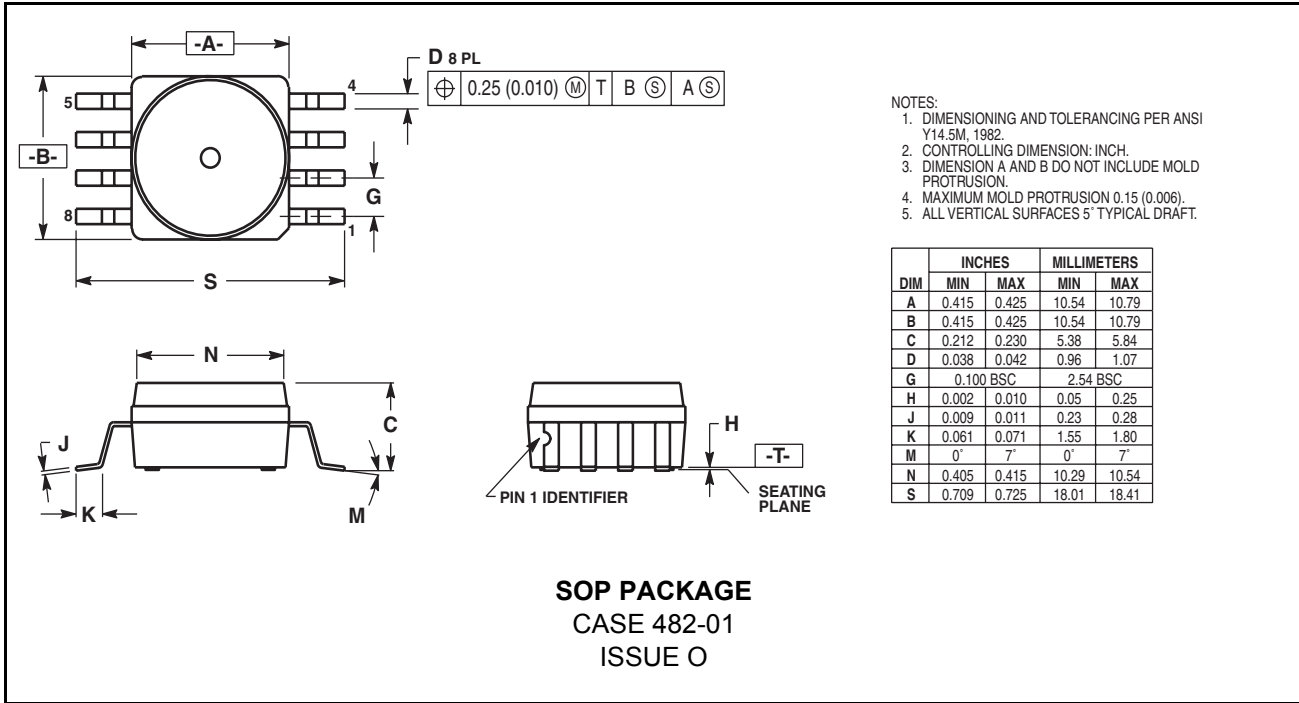


**Figure 4. Reel**

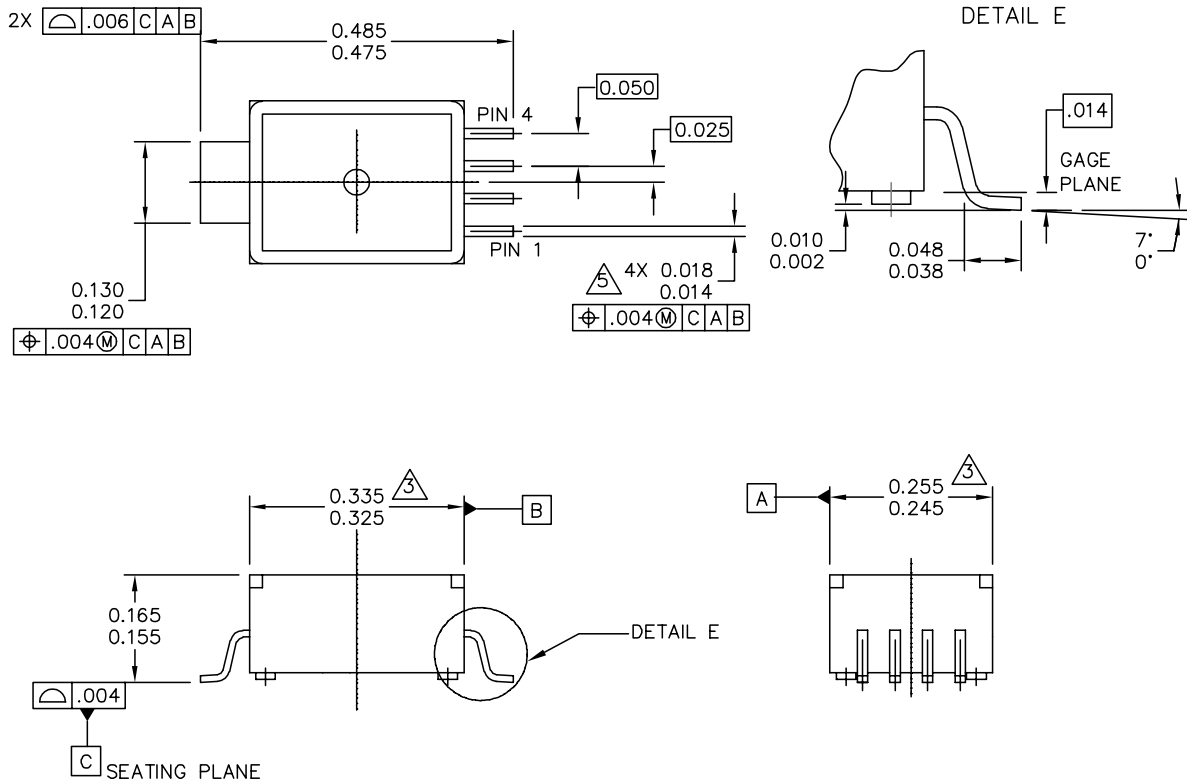


**Figure 5. Orientation of Small Outline Package Sensor Device**

## PACKAGE DIMENSIONS



# PACKAGE DIMENSIONS



© FREESCALE SEMICONDUCTOR, INC. ALL RIGHTS RESERVED.	<b>MECHANICAL OUTLINE</b>	PRINT VERSION NOT TO SCALE	
TITLE:  5 LD M-PAC	DOCUMENT NO: 98ARH99088A	REV: B	
	CASE NUMBER: 1320-02	22 JUL 2005	
	STANDARD: NON-JEDEC		

**MPAK PACKAGE**  
CASE 1320-02  
ISSUE B

## PACKAGE DIMENSIONS

NOTES:

1. DIMENSIONS ARE IN INCHES.
2. INTERPRET DIMENSIONS AND TOLERANCES PER ASME Y14.5M-1994.
3. DIMENSION DOES NOT INCLUDE MOLD FLASH OR PROTRUSION. MOLD FLASH OR PROTRUSION SHALL NOT EXCEED .006" PER SIDE.
4. ALL VERTICAL SURFACES TO BE 5° MAXIMUM.
5. DIMENSION DOES NOT INCLUDE DAMBAR PROTRUSION. ALLOWABLE DAMBAR PROTRUSION SHALL BE .008 MAXIMUM.

PIN 1: GND  
 PIN 2: +Vout  
 PIN 3: Vs  
 PIN 4: -Vout

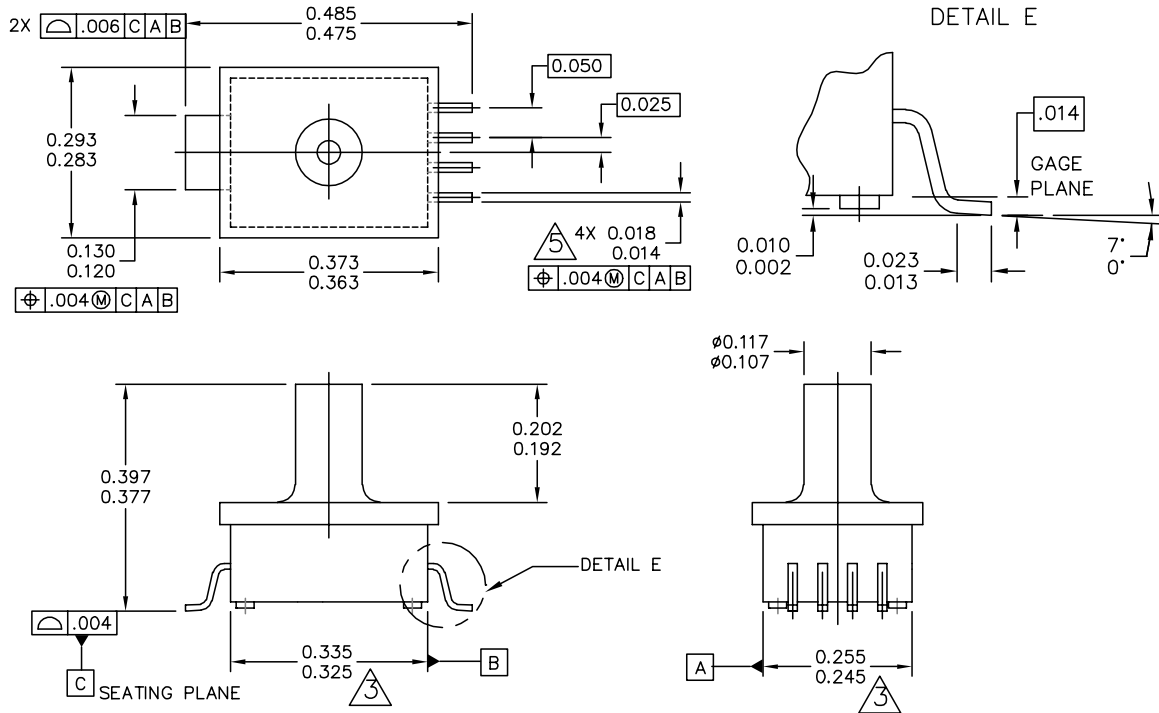
© FREESCALE SEMICONDUCTOR, INC. ALL RIGHTS RESERVED.	<b>MECHANICAL OUTLINE</b>	PRINT VERSION NOT TO SCALE	
TITLE:  <div style="text-align: center; margin-top: 20px;">5 LD M-PAC</div>	DOCUMENT NO: 98ARH99088A	REV: B	
	CASE NUMBER: 1320-02	22 JUL 2005	
	STANDARD: NON-JEDEC		

PAGE 2 OF 2

**MPAK PACKAGE**  
 CASE 1320-02  
 ISSUE B

**AN1984**

# PACKAGE DIMENSIONS



© FREESCALE SEMICONDUCTOR, INC. ALL RIGHTS RESERVED.	<b>MECHANICAL OUTLINE</b>	PRINT VERSION NOT TO SCALE	
TITLE: 5 LD M-PAC, PORTED	DOCUMENT NO: 98ARH99087A	REV: A	
	CASE NUMBER: 1320A-02	22 JUL 2005	
	STANDARD: NON-JEDEC		

PAGE 1 OF 2

**MPAK PACKAGE**  
CASE 1320A-02  
ISSUE A



## PACKAGE DIMENSIONS

NOTES:

1. DIMENSIONS ARE IN INCHES.

2. INTERPRET DIMENSIONS AND TOLERANCES PER ASME Y14.5M-1994.

3. DIMENSIONS DOES NOT INCLUDE MOLD FLASH OR PROTRUSION. MOLD FLASH OR PROTRUSION SHALL NOT EXCEED .006" PER SIDE.

4. ALL VERTICAL SURFACES TO BE 5" MAXIMUM.

5. DIMENSION DOES NOT INCLUDE DAMBAR PROTRUSION. ALLOWABLE DAMBAR PROTRUSION SHALL BE .008 MAXIMUM.

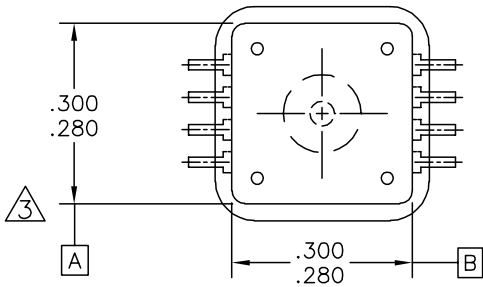
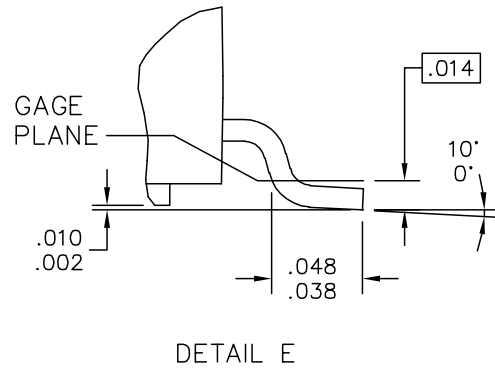
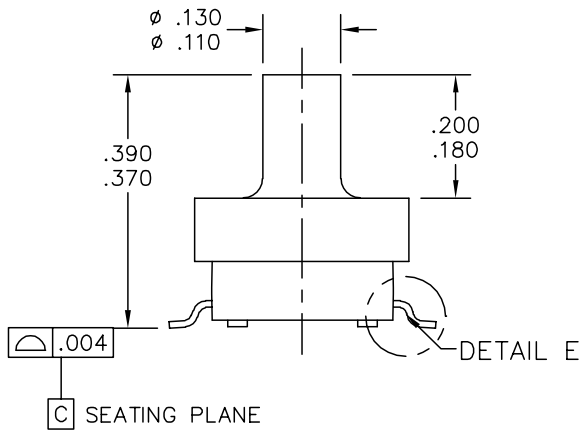
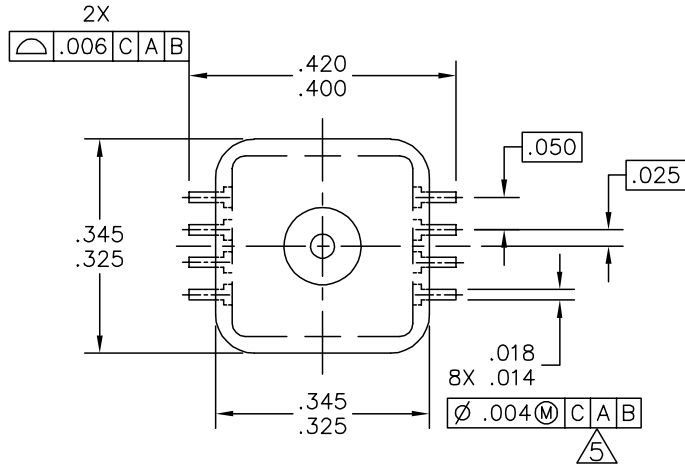
© FREESCALE SEMICONDUCTOR, INC. ALL RIGHTS RESERVED.	<b>MECHANICAL OUTLINE</b>	PRINT VERSION NOT TO SCALE	
TITLE: 5 LD M-PAC, PORTED	DOCUMENT NO: 98ARH99087A	REV: A	
	CASE NUMBER: 1320A-02	22 JUL 2005	
	STANDARD: NON-JEDEC		

PAGE 2 OF 2

**MPAK PACKAGE**  
CASE 1320A-02  
ISSUE A

**AN1984**

# PACKAGE DIMENSIONS



© FREESCALE SEMICONDUCTOR, INC. ALL RIGHTS RESERVED.	<b>MECHANICAL OUTLINE</b>	PRINT VERSION NOT TO SCALE	
TITLE:  8 LD, PORTED SSOP	DOCUMENT NO: 98ARH99089A		REV: C
	CASE NUMBER: 1317A-03		24 MAY 2005
	STANDARD: NON-JEDEC		

PAGE 1 OF 2

**SSOP PACKAGE**  
CASE 1317A-03  
ISSUE C

## PACKAGE DIMENSIONS

### NOTES:

1. ALL DIMENSIONS IN INCHES.
2. DIMENSIONING AND TOLERANCING PER ASME Y14.5M-1994.
3. DIMENSIONS DO NOT INCLUDE MOLD FLASH OR PROTRUSIONS.  
MOLD FLASH OR PROTRUSION SHALL NOT EXCEED .006 INCHES PER SIDE.
4. ALL VERTICAL SURFACES TO BE 5° MAXIMUM.
5. DIMENSION DOES NOT INCLUDE DAMBAR PROTRUSION.  
ALLOWABLE DAMBAR PROTRUSION SHALL BE .008 INCHES MAXIMUM.

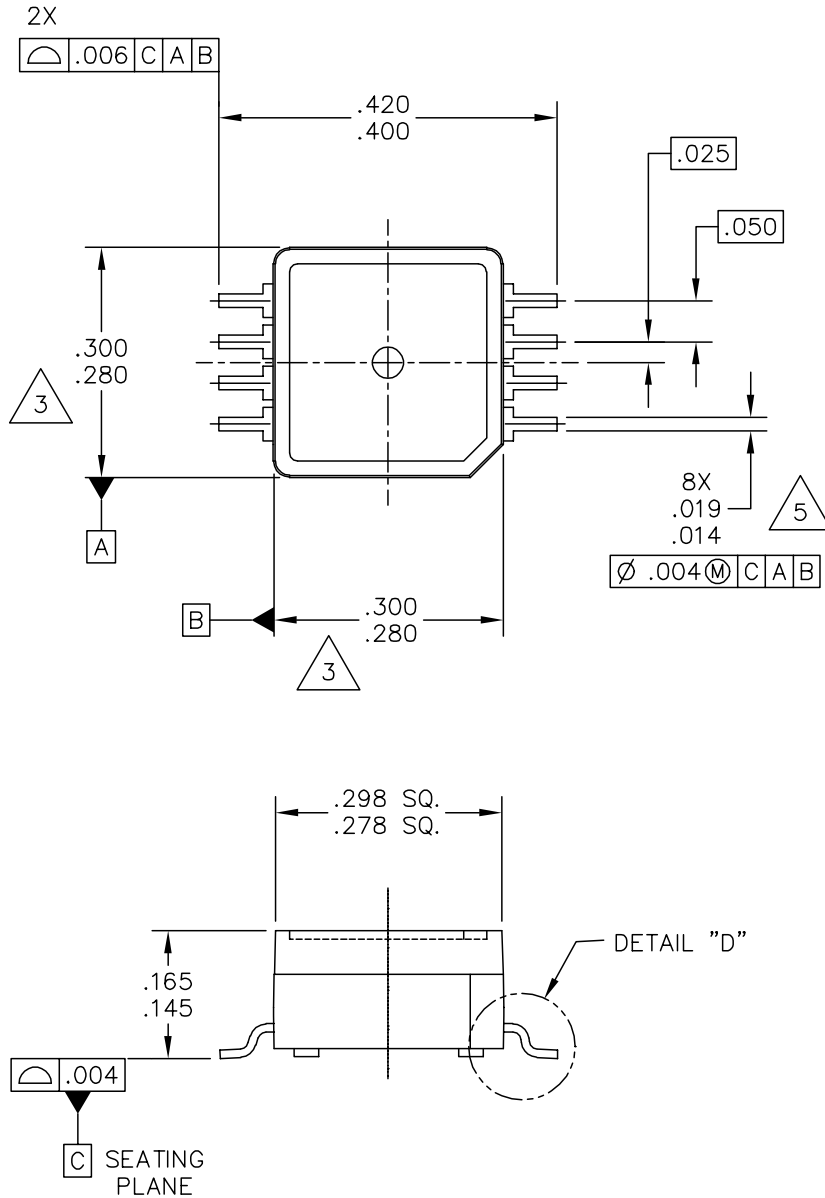
© FREESCALE SEMICONDUCTOR, INC. ALL RIGHTS RESERVED.	<b>MECHANICAL OUTLINE</b>	PRINT VERSION NOT TO SCALE	
TITLE:  8 LD, PORTED SSOP	DOCUMENT NO: 98ARH99089A	REV: C	
	CASE NUMBER: 1317A-03	24 MAY 2005	
	STANDARD: NON-JEDEC		

PAGE 2 OF 2

**SSOP PACKAGE**  
CASE 1317A-03  
ISSUE C

**AN1984**

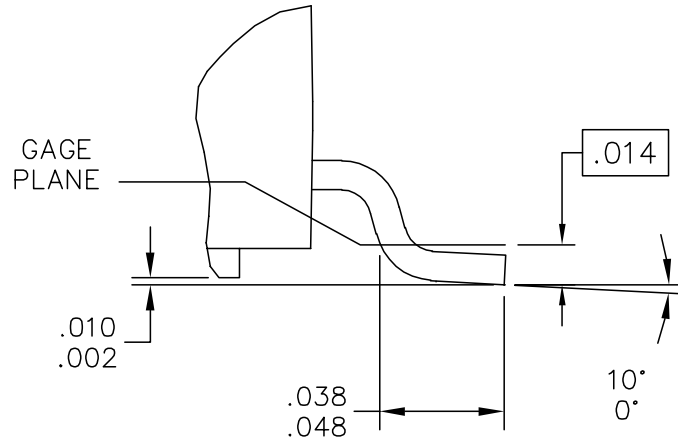
## PACKAGE DIMENSIONS



© FREESCALE SEMICONDUCTOR, INC. ALL RIGHTS RESERVED.	<b>MECHANICAL OUTLINE</b>	PRINT VERSION NOT TO SCALE
TITLE:           8 LEAD SSOP	DOCUMENT NO: 98ARH99066A CASE NUMBER: 1317-04 STANDARD: NON-JEDEC	REV: F 24 MAY 2005

**SSOP PACKAGE**  
 CASE 1317-04  
 ISSUE F

**PACKAGE DIMENSIONS**



DETAIL "D"

© FREESCALE SEMICONDUCTOR, INC. ALL RIGHTS RESERVED.	<b>MECHANICAL OUTLINE</b>	PRINT VERSION NOT TO SCALE	
TITLE: 8 LEAD SSOP	DOCUMENT NO: 98ARH99066A	REV: F	
	CASE NUMBER: 1317-04	24 MAY 2005	
	STANDARD: NON-JEDEC		

**SSOP PACKAGE**  
CASE 1317-04  
ISSUE F

## PACKAGE DIMENSIONS

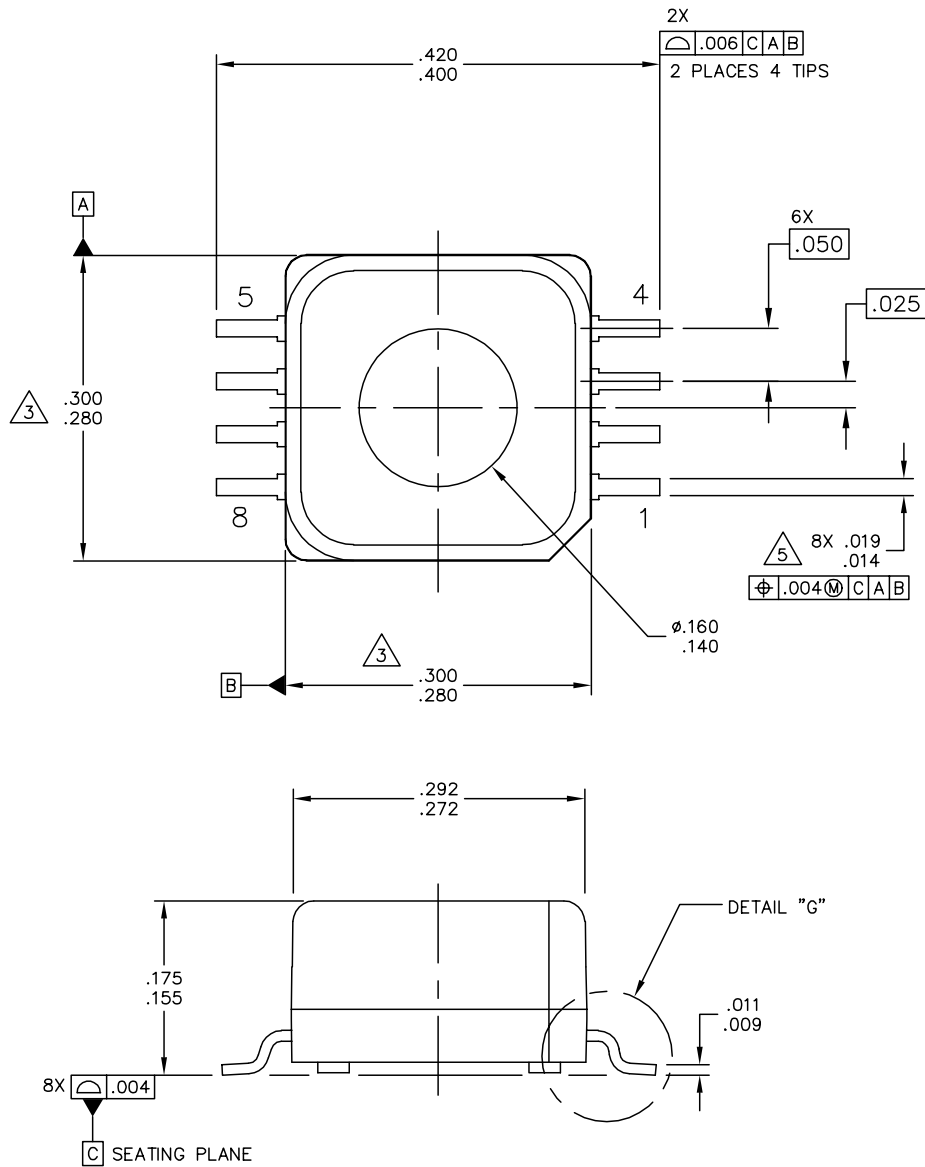
NOTES:

1. ALL DIMENSIONS IN INCHES.
2. DIMENSIONING AND TOLERANCING PER ASME Y14.5M-1994.
3. DIMENSIONS DO NOT INCLUDE MOLD FLASH OR PROTRUSIONS.  
MOLD FLASH OR PROTRUSION SHALL NOT EXCEED .006 INCHES PER SIDE.
4. ALL VERTICAL SURFACES TO BE 5° MAXIMUM.
5. DIMENSION DOES NOT INCLUDE DAMBAR PROTRUSION.  
ALLOWABLE DAMBAR PROTRUSION SHALL BE .008 INCHES MAXIMUM.

© FREESCALE SEMICONDUCTOR, INC. ALL RIGHTS RESERVED.	<b>MECHANICAL OUTLINE</b>	PRINT VERSION NOT TO SCALE	
TITLE:           8 LEAD SSOP	DOCUMENT NO: 98ARH99066A	REV: F	
	CASE NUMBER: 1317-04	24 MAY 2005	
	STANDARD: NON-JEDEC		

**SSOP PACKAGE**  
 CASE 1317-04  
 ISSUE F

# PACKAGE DIMENSIONS



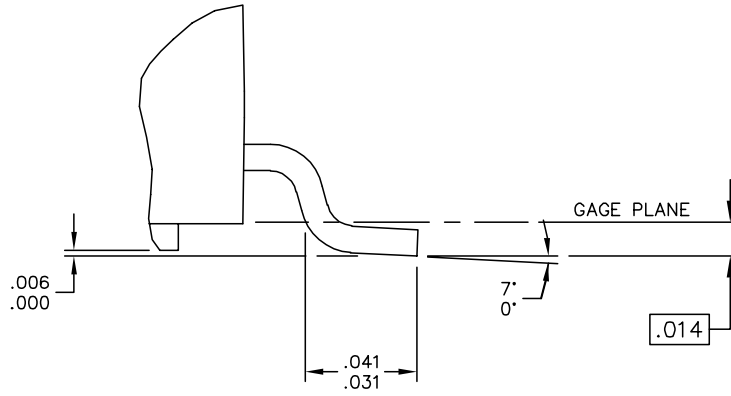
© FREESCALE SEMICONDUCTOR, INC. ALL RIGHTS RESERVED.	<b>MECHANICAL OUTLINE</b>	PRINT VERSION NOT TO SCALE	
TITLE:  8 LEAD TPMP GULL WING FORM	DOCUMENT NO: 98ASA99256D	REV: C	
	CASE NUMBER: 1352-03	24 JUL 2005	
	STANDARD: NON-JEDEC		

PAGE 1 OF 3

**SSOP PACKAGE**  
CASE 1352-03  
ISSUE C

**AN1984**

**PACKAGE DIMENSIONS**



DETAIL "G"

© FREESCALE SEMICONDUCTOR, INC. ALL RIGHTS RESERVED.	<b>MECHANICAL OUTLINE</b>	PRINT VERSION NOT TO SCALE	
TITLE: 8 LEAD TPMP GULL WING FORM	DOCUMENT NO: 98ASA99256D	REV: C	
	CASE NUMBER: 1352-03	24 JUL 2005	
	STANDARD: NON-JEDEC		

**SSOP PACKAGE**  
CASE 1352-03  
ISSUE C



## PACKAGE DIMENSIONS

### NOTES:

1. CONTROLLING DIMENSION: INCH.
2. INTERPRET DIMENSIONS AND TOLERANCES PER ASME Y14.5M-1994.
3. DIMENSIONS DO NOT INCLUDE MOLD FLASH OR PROTRUSIONS. MOLD FLASH AND PROTRUSIONS SHALL NOT EXCEED .006 PER SIDE.
4. ALL VERTICAL SURFACES TO BE 5° MAXIMUM.
5. DIMENSION DOES NOT INCLUDE DAMBAR PROTRUSION. ALLOWABLE DAMBAR PROTRUSION SHALL BE .008 MAX.

© FREESCALE SEMICONDUCTOR, INC. ALL RIGHTS RESERVED.	<b>MECHANICAL OUTLINE</b>	PRINT VERSION NOT TO SCALE	
TITLE: 8 LEAD TPMP GULL WING FORM	DOCUMENT NO: 98ASA99256D	REV: C	
	CASE NUMBER: 1352-03	24 JUL 2005	
	STANDARD: NON-JEDEC		

PAGE 3 OF 3

**SSOP PACKAGE**  
CASE 1352-03  
ISSUE C

**AN1984**

## **How to Reach Us:**

### **Home Page:**

[www.freescale.com](http://www.freescale.com)

### **Web Support:**

<http://www.freescale.com/support>

### **USA/Europe or Locations Not Listed:**

Freescale Semiconductor, Inc.  
Technical Information Center, EL516  
2100 East Elliot Road  
Tempe, Arizona 85284  
+1-800-521-6274 or +1-480-768-2130  
[www.freescale.com/support](http://www.freescale.com/support)

### **Europe, Middle East, and Africa:**

Freescale Halbleiter Deutschland GmbH  
Technical Information Center  
Schatzbogen 7  
81829 Muenchen, Germany  
+44 1296 380 456 (English)  
+46 8 52200080 (English)  
+49 89 92103 559 (German)  
+33 1 69 35 48 48 (French)  
[www.freescale.com/support](http://www.freescale.com/support)

### **Japan:**

Freescale Semiconductor Japan Ltd.  
Headquarters  
ARCO Tower 15F  
1-8-1, Shimo-Meguro, Meguro-ku,  
Tokyo 153-0064  
Japan  
0120 191014 or +81 3 5437 9125  
[support.japan@freescale.com](mailto:support.japan@freescale.com)

### **Asia/Pacific:**

Freescale Semiconductor Hong Kong Ltd.  
Technical Information Center  
2 Dai King Street  
Tai Po Industrial Estate  
Tai Po, N.T., Hong Kong  
+800 2666 8080  
[support.asia@freescale.com](mailto:support.asia@freescale.com)

### **For Literature Requests Only:**

Freescale Semiconductor Literature Distribution Center  
P.O. Box 5405  
Denver, Colorado 80217  
1-800-441-2447 or 303-675-2140  
Fax: 303-675-2150  
[LDCForFreescaleSemiconductor@hibbertgroup.com](mailto:LDCForFreescaleSemiconductor@hibbertgroup.com)

Information in this document is provided solely to enable system and software implementers to use Freescale Semiconductor products. There are no express or implied copyright licenses granted hereunder to design or fabricate any integrated circuits or integrated circuits based on the information in this document.

Freescale Semiconductor reserves the right to make changes without further notice to any products herein. Freescale Semiconductor makes no warranty, representation or guarantee regarding the suitability of its products for any particular purpose, nor does Freescale Semiconductor assume any liability arising out of the application or use of any product or circuit, and specifically disclaims any and all liability, including without limitation consequential or incidental damages. "Typical" parameters that may be provided in Freescale Semiconductor data sheets and/or specifications can and do vary in different applications and actual performance may vary over time. All operating parameters, including "Typicals", must be validated for each customer application by customer's technical experts. Freescale Semiconductor does not convey any license under its patent rights nor the rights of others. Freescale Semiconductor products are not designed, intended, or authorized for use as components in systems intended for surgical implant into the body, or other applications intended to support or sustain life, or for any other application in which the failure of the Freescale Semiconductor product could create a situation where personal injury or death may occur. Should Buyer purchase or use Freescale Semiconductor products for any such unintended or unauthorized application, Buyer shall indemnify and hold Freescale Semiconductor and its officers, employees, subsidiaries, affiliates, and distributors harmless against all claims, costs, damages, and expenses, and reasonable attorney fees arising out of, directly or indirectly, any claim of personal injury or death associated with such unintended or unauthorized use, even if such claim alleges that Freescale Semiconductor was negligent regarding the design or manufacture of the part.

Freescale™ and the Freescale logo are trademarks of Freescale Semiconductor, Inc. All other product or service names are the property of their respective owners.

© Freescale Semiconductor, Inc. 2006. All rights reserved.

